

Breezee[®]
NUMBER ONE IN NATURAL COOLING



You deserve Australia's best



**Cool your whole home from
as little as running a light globe**

SEELEY
INTERNATIONAL 

**AUSTRALIAN
MADE**
Wise Australian
buys Australian 



Frank Seeley AM FAICD
2011 South Australian of the Year,
Founder and Executive Chairman.

With a history of innovation and quality, the Breezair range, manufactured by Seeley International, delivers quiet and powerful cooling that's energy efficient, so it's kind to the environment as well as to you.

The first corrosion-free, all-plastic rooftop evaporative air conditioner, and the first and only evaporative air conditioner with mega-energy-saving inverter technology, Breezair is the market leader in Australia and leads the world in evaporative cooling technology.

Breezair is one of the many leading brands manufactured by Seeley International, Australia's largest air conditioning manufacturer. 100% Australian owned, Seeley International now exports Australian-made products to well over 100 countries under the award-winning brand names Braemar, Climate Wizard, Coolair, Convair as well as Breezair.

Today, more than ever you can trust Breezair for keeping your home cool without costing the earth, all with a reassuring 5 year warranty.

Cooler. Fresher. Quieter.

Your home deserves the finest ducted evaporative air conditioning available.

So it makes good sense to choose the revolutionary Breezair Icon - the world's quietest and most efficient ducted evaporative air conditioning system.

The technology built into Breezair is the best in the world and your guarantee of the ultimate in comfort, economy and cooling power.

Install Breezair... it's the name you can trust.



**Breezair...
makes me
feel great**

Some of Seeley International's awards...

BRW Most Innovative Companies Top 30 List
- Number 14
Seeley International

Manufacturers' Monthly Lifetime Achievement Award
- Winner
Frank Seeley AM FAICD

Manufacturers' Monthly Australian Consumer/Trade Product of the Year Award
- Winner
Braemar Six Star Ducted Gas Heating Range

Australian Design Awards - Housing and Building Design Award™ Good Design Award
- Winner
Braemar world's first five star non-condensing ducted gas heating range

Australian Design Awards - Housing and Building Design Award™ Good Design Award
- Winner
Braemar world's first six star ducted gas heating range

Australian Innovation Challenge Awards
- Finalist
Climate Wizard

Advantage SA
- South Australian of The Year Award
Frank Seeley AM FAICD

AIRAH Awards
- Winner: Award for Excellence in Innovation
Climate Wizard

49th Australian Export Awards
- Finalist
Seeley International

Business SA Export Awards
- Winner: Large Advanced Manufacturer SA

Australian Design Awards
- Winner Housing and Building Design Award™
Climate Wizard

Australia's Best Manufacturing Magazine
- Platinum Award for supply-chain and purchasing excellence
Seeley International, Frank Seeley AM FAICD

Manufacturers' Monthly 2011 Endeavour Awards
- Winner: Australian Consumer/Trade Product of the Year Award
Climate Wizard

Manufacturers' Monthly 2011 Endeavour Awards
- Finalist: Australian Industrial Product of the Year Award
Climate Wizard

NSW GAS Awards for Excellence
- Winner: Industry Category - Environmentally Sustainable Product
Braemar Gas Heating



Breezair... better because



Australian designed and built, Hushpower's motor technology leads the world in quiet cooling. The fact is, nothing cools as quietly or as effectively as the revolutionary Hushpower Icon.



Nothing cools as quietly

The thing you immediately notice about the world class Breezair Icon series is how wonderfully cool it makes your home feel, and how quietly it operates – it's incredibly quiet.

In fact nothing comes close to the unobtrusive cooling power of the Breezair Icon series.

It's all thanks to the superior design of Breezair's ground-breaking centrifugal fan and Hushpower motor, a global revolution in air conditioning engineering.

Old-fashioned axial fan systems are noisy because they spin like helicopter blades which creates air turbulence.

Superior design, better comfort

But the Breezair Hushpower motor and centrifugal fan combination is better designed, better built and simply does the job a whole lot better as it pushes a strong, even flow of fresh, cool air to all corners of your home.

Internationally acclaimed as the world's quietest and most innovative fan system, Icon's whisper-quiet operation is remarkable. There's barely a sound inside or outside your home - so not only will you love the way Icon quietly cools, your neighbours will too!

The name to trust

For over thirty years Breezair has been globally acknowledged as the leader in evaporative air conditioning technology – technology that Breezair exports around the world and expertise you can rely upon to quietly cool your home through even the harshest Australian summer.



Breezair... the quiet revolution in cooling



**Revolutionary Hushpower
fan and motor technology
makes Breezair the
world's best**

Breezair... better because



- Lowest operating costs of any comparable system
- Economical purchase and installation costs
- Advanced system management that minimises power and water usage



Count the savings

Imagine being able to keep your family comfortably cool all summer long for as little as \$25 per year in electricity costs*.

Wherever you live in Australia, Breezair technology will cost less to cool your home than any other comparable system.

Icon's world-renowned cooling efficiency uses much less energy. Even more impressive is Icon's miserly seasonal power consumption - under half that of any competitive brand.

It's little wonder that with Breezair, you can cool your entire home from as little as the cost of running a light globe.

Exclusive Invertacool™ technology

Trust Breezair to be the first, and only, evaporative cooling system with mega-energy-saving Inverter technology. Breezair's Invertacool™ is an amazing innovation that saves you money on operating costs year after year, after year.

Invertacool™ cleverly manages power consumption which adds up to greatly reduced energy use, improved performance and genuine cost savings...and, only Breezair has it!

Compucool®... for a smarter design

Compucool® is another brilliant example of Breezair innovation. Exclusive to your Breezair consultant, the intelligent Compucool® design program uses computerised accuracy to profile your home's key architectural aspects and ensure the optimum system for your home and your budget.



Breezair... cooling that costs far less

* Based on average Melbourne summer at 148m² cooling over 25°C

Look at the savings with Breezair

Hourly running cost

Sustainable Energy Victoria "Choosing a cooling system", November 2002

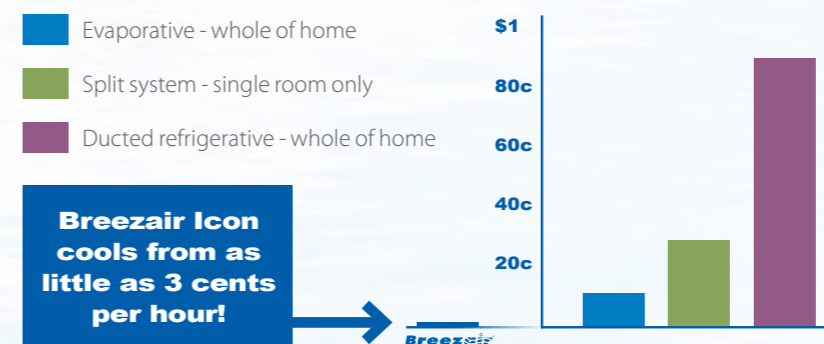

**Breezair Icon
cools from as
little as 3 cents
per hour!**

**Breezair...
better
because**



Breezair evaporative air conditioning is ideal for asthmatics, children and the elderly because it continually circulates a fresh supply of clean, filtered air throughout your home.



Fresh as a sea breeze

Step inside a Breezair-cooled home and you'll quickly notice how refreshingly cool it feels.

One of the major benefits of Breezair evaporative air conditioning is the way it fills your home with fresh, filtered, cool air – it's as natural as a soothing sea breeze.

Unlike refrigerated systems, Breezair does not continually recycle stale air - it actually completely replaces the air within your home every few minutes.

Summer is for living

For those who enjoy entertaining outdoors, for families with children, and for people who simply prefer **fresh rather than recycled air** Breezair is unquestionably the best choice.

That's because only evaporative air conditioning allows doors and windows to remain open whenever it is operating. Cooling performance is unaffected by people coming and going, which makes Breezair a perfect companion to the relaxed Australian lifestyle.

Breezair, a better option

When it comes to choosing a cooling system for your home the advantages of the Breezair Icon Series are simply too good to ignore.

Superior comfort, better economy, outstanding efficiency, unsurpassed reliability, clever convenience benefits, ease of use... it's easy to see why the technological excellence built into every Breezair Icon series model is unmatched anywhere or by any other brand.



**Breezair...
for you,
your family,
your lifestyle**

Why Breezair is better for your lifestyle

Breezair	Refrigerated
Cost	
Economical – significantly lower operating costs.	Can cost as much as 80% more to operate than a Breezair system.
Cooling	
Natural airflow is ideal for asthmatics, children and the elderly.	Dries the eyes, skin and household plants.
Operation	
Continuous flow of fresh clean filtered air – completely replaces air every few minutes.	Re-circulates stale air. Potential for bad odours and unhealthy environment.

Breezair... better because



Breezair roof-top cabinets are injection-moulded from durable, UV-stabilised polymers with additives for high impact strength. This ensures a product that is structurally superior and far stronger than units made from thin, vacuum-formed plastic.



Colour range



Slate grey

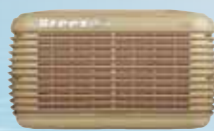

Beige



Terracotta



Heritage green

Breezair® specifications and cooling performance in kW

Model	Nominal Power Motor (w)	Width (mm)	Depth (mm)	Height (mm)	Shipping Weight (kg)	Actual (kW) of cooling
EXH130	500	1160	1160	660	71	8.4
EXH150	550	1160	1160	860	77	9.8
EXH170	750	1160	1160	860	77	12.6
EXH190	1100	1160	1160	860	77	14.4
EXH210	1500	1160	1160	860	78	15.5
EZH215	1500	1160	1160	1240	89	15.4

The above data was drawn from Meridian Laboratories test analysis. The testing was performed by a NATA accredited laboratory to the requirements of the Australian standard AS2913-2000*Evaporative Air Conditioning Equipment. Achievable with ambient 38°C DB, 21°C WB, room temperature 27.4°C.

Cooling performance comparison

Seeley International, manufacturers of Breezair, has tested its Evaporative Coolers according to AS2913-2000. This is the Australian Standard for the testing of Fixed Evaporative Air conditioners and demands that all such air conditioners be tested as complete units. The standard states in clause 3.1.1d-1 "Performance ratings relate to the actual performance of the fully assembled equipment as supplied, not to the component parts prior to assembly." Australian Standard AS2913-2000. All test results commissioned by Seeley International of both their own and competitive air conditioners, have been carried out in this prescribed manner. Based on AUSTRALIAN STANDARD mandatory testing procedure, published above are the actual cooling performances for various Breezair models.

Ahead of the rest, by far

Breezair's engineering sets a new standard for cooling performance and reliability. Whether you live in Birdsville or Bondi, Icon's leading-edge cooling technology won't let you down. That's because Breezair is designed and built in Australia to withstand even the harshest Australian summer. With rugged and clever design features such as these, Breezair will keep you and your family comfortably cool for years to come...

- Corrosion-free materials
- Injection moulded cabinets and components that will not rust or fade
- UV stabilised polymers
- Long life Chillcel® pads
- Revolutionary WATERmiser™ monitor
- Powerful Tornado® pump
- Amazing auto Clean and Dry function
- Anti-clog water distribution

Looks that are built to last

Designed to blend discretely with the roofline of your home, Breezair's world renowned Permatuf® cabinets look great and won't crack, peel or warp.

Manufactured in Australia from UV stabilised polymer, the injection moulded cabinets are virtually impervious to our harsh climate and will retain their good-as-new looks year after year.

Complete peace of mind

A rigid quality control testing policy to Australian Standard ISO 9001 ensures that Breezair Icon series air conditioners live up to their hard-earned reputation for outstanding reliability.

For additional peace of mind, Breezair backs every one of its air conditioning systems with an industry leading comprehensive warranty program - including 10-years on all structural components, plus a hefty 25-year cover on the Permatuf® cabinets.



Breezair... performance you can trust

10
years

10 year structural warranty

5
years

5 year general warranty

25
years

25 year permatuf cabinet warranty

Breezair... better because



There's no need to worry about Legionella with Breezair. The circumstances needed for this bacteria to proliferate can not exist in wet-pad evaporative systems.

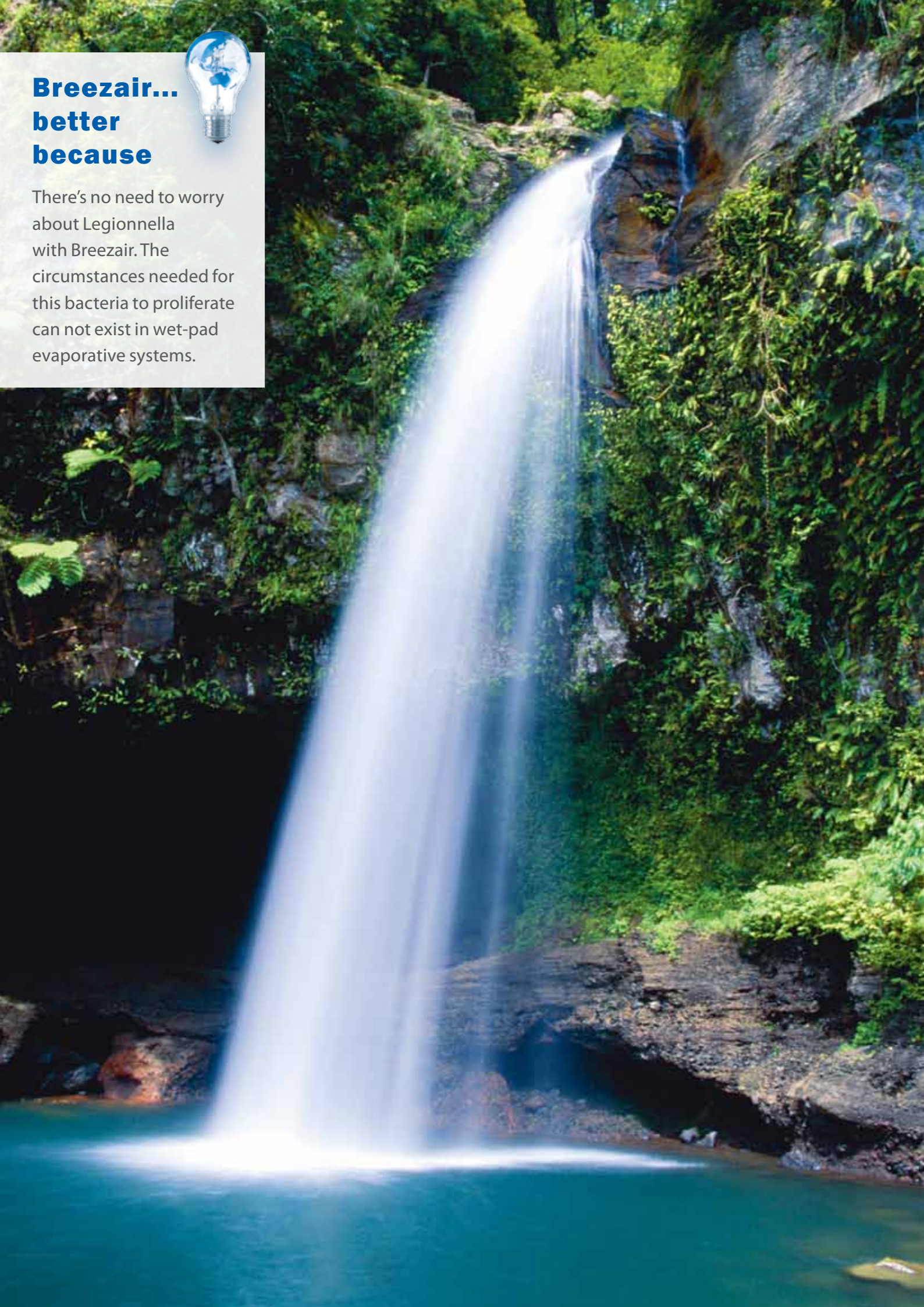

A healthy choice

For air conditioning that fills your home with fresh, cool, clean air, Breezair is unquestionably your best choice.

That's because Breezair completely replaces the air within your home every few minutes. Fresh air is drawn through moistened Chillcel® pads where it is filtered and cooled before being gently circulated throughout your home.

It's a process as natural as a sea breeze, giving you continuous fresh air instead of stale, recirculated air from a refrigerated system.

It's also much gentler on the eyes, nose and skin because evaporative air conditioning doesn't have the aggressive drying effect that occurs with refrigerated systems.

Naturally better

The power consumption of just one ducted refrigerative air conditioner can result in up to three tonnes of harmful CO₂ being pumped into the atmosphere each year (SEAV, "Choosing a cooling system", November 2002).

On the other hand, Breezair's Icon evaporative air conditioning system is so efficient it produces less than one tenth of this volume.

By choosing Breezair, you can help reduce the amount of harmful greenhouse emissions entering our environment.



Breezair... naturally better



WATERMiser™ monitors water quality to reduce consumption, minimise waste and eliminate unnecessary dumping of water

Breezair... better for the environment

- Ducted refrigerative
– whole of home
- Split system
– single room only
- Evaporative system
– whole of home

Tonnes of CO₂ per year

Sustainable Energy Victoria "Choosing a cooling system", November 2002

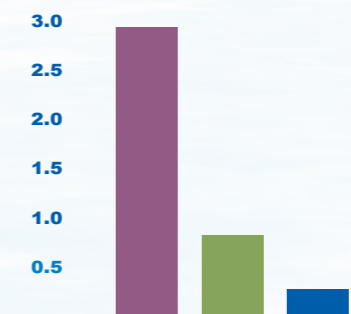

Why is Breezair unique?



New Icon® Series fan

- Combined motor and fan
- Ultra-quiet centrifugal fan
- Responsive to duct sizing and back-pressure
- Designed to deliver optimum air output



Hushpower® direct drive motor

- Exclusive to Breezair
- Incredibly quiet and efficient throughout operating range
- Uses far less energy
- Unsurpassed reliability
- Corrosion-proofed throughout



WATERmiser™

- Uses the minimum amount of water to achieve high efficiency cooling
- Water quality monitoring for significant water savings
- Leak detection monitor



Tornado® pump

- Australian designed and manufactured
- Exceptional reliability in extreme conditions

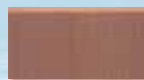

Long life Chillcel® pads

- Honeycomb design optimises the cooling effect
- Durable design outlasts competitive products



Non clogging water distribution

- Unique design ensures constant, even pad saturation
- Maximises the cooling effect - outperforms competitive products



Clean and dry function

- Automatic water draining when the system is not in use
- Prevents algae growth
- Avoids the seasonal maintenance required by competitive products



Power control module

- Advanced electronics ensure maximum efficiency
- Microprocessor constantly analyses water quality, water consumption and power output
- Smart, reliable and durable

Weatherseal®

- Automatic sealing system
- Reduces draughts and dust
- Reduces need for winter cover

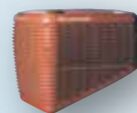

Mirage rooftop unit

- The Mirage models' raked-base design and low profile hugs the slope of your roof
- Virtually invisible from street-level.

Optional extras:

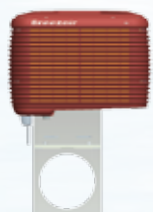

Firewall Auto-seal

- Helps prevent ember attack in bushfires
- Metal flap that isolates the cooler from the duct work
- When fitted, the Breezair unit complies with
 - Bushfire Attack Level rating BAL-LOW through to BAL-29 (AS3959)
 - The Building Code of Australia

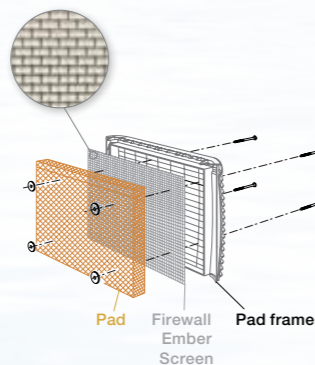

Firewall ember screen

- Helps guard against ember attack in bushfires
- Made from non-combustible mesh
- Maximum aperture of 2mm
- Can be fitted to existing cooler pad frames
- Minimal reduction of air flow at 5%

Features and benefits

Everything about the Breezair Icon series points to outstanding performance. In fact no other evaporative air conditioning product offers such world-class technology.

	EXH series Homemaker	EXH & EZH series Harmony	Horizon
Ease of use			
SensorTouch® wall control	✓	✓	
SensorTouch® remote control			✓
LCD display	✓	✓	✓
Comfort			
Thermostatic control	✓	✓	✓
Ten comfort level settings	✓	✓	✓
Pre-cool cycle (optional setting)	✓	✓	✓
AUTOWeatherseal™ damper reduces draughts	✓	✓	✓
Ventilation setting	✓	✓	✓
Convenience			
Programmable timer (one event)	✓	✓	✓
24 hour auto repeat timer			✓
Time of day clock display			✓
Clean and dry function		✓	✓
Design			
Rounded, softer, low profile design	✓	✓	✓
Available in a range of colours	✓	✓	✓
Reliability			
Permatuf® polymer injection moulded construction lasts longer	✓	✓	✓
General warranty	5 year	5 year	5 year
Structural warranty	10 year	10 year	10 year
Cabinet warranty	25 year	25 year	25 year
Performance			
Super efficient Hushpower® motor	✓	✓	✓
Ultra cheap to run	✓	✓	✓
Energy save setting			✓
90mm thick Chillcel® pads	✓	✓	✓
Unique non-clogging water distributor for better cooling	✓	✓	✓
Quiet, lightweight centrifugal fan	✓	✓	✓
Super efficient WATERmiser™		✓	✓
Service			
Fully trained accredited dealer network	✓	✓	✓
Australia's leading brand	✓	✓	✓

While this product complies with all Australian and International Standards for Electromagnetic Compatibility, in remote areas and other areas of marginal television and radio reception there is the potential that the Icon's advanced electronics could interfere with the transmission signal.



Homemaker/Harmony SensorTouch® wall controller

- Back-lit screen
- Space-efficient, easy-to-find, unobtrusive wall mount
- Variable climate control



Horizon optional remote control

- Glow in the dark controls
- Variable climate adjustment
- User friendly
- Drain feature

Seeley International

Seeley International is Australia's largest air conditioning and ducted gas heating manufacturer and a global leader in developing ingenious, energy-efficient cooling and heating products.

Our vision is to lead the world in creating climate control solutions which continue to be highly innovative, of premium quality and inspirational in their delivery of energy-efficiency.

But it's more than just a vision... it's a way of life!

A commitment to innovation and excellence is at the heart of all that we do. Our success in delivering on that commitment has been recognised by our many awards and our expanding global presence. Seeley International now exports to well over 100 countries. Not bad for a company that started out in 1972 in the garage of its founder and Chairman, Frank Seeley AM FAICD, who was named South Australian of the Year for 2011!



*Haier air conditioning products are proudly distributed by Seeley International throughout Australia.

To locate your nearest accredited Breezair dealer call 1300 360 651 or go to breezair.com.au

Please visit www.breezair.com.au to find out more about our current promotions.*

*Promotions are seasonal and do not run at all times of the year.

Seeley International Pty Ltd

ABN 23 054 687 035

112 O'Sullivan Beach Road
Lonsdale, South Australia 5160

Phone (08) 8328 3850

Fax (08) 8328 3951

Email marketing@seeleyinternational.com

Web seeleyinternational.com

Information in this brochure was correct at the time of preparation.

E & OE



Quality
ISO 9001

SAI GLOBAL